



## GUARDING SYSTEM INSTALLATION MANUAL

600, 900, 1200 GUARDING

Patent Pending



This Installation Manual is provided as an assembly guide for the Sentry Guarding System. Refer to the Brochure for recommended layouts for various job site conditions. The product may be unstable during installation until fully assembled. Proper safety measures must be taken at all times. **Product may fail and void warranty if guarding is not correctly assembled and installation does not comply with standards, design guide and drawings.**

Sentry Guarding System has been designed and tested to comply with: AS/NZS 4024.3610/3611 - Safety of Machinery - Conveyors.

## Safety & General Information

### Equipment Required

#### Tools

- 17mm ring spanner
- Blind nut riveter kit (M10)
- Rivet gun
- 10mm hex key

#### Personal Protective Equipment

- Safety glasses
- Protective gloves
- Safety footwear

### POST ASSEMBLY

#### Step 1

Install M10 Stainless Steel rivet nut with large flange using a blind nut riveter.

#### Step 2

Tighten Mild Steel / Stainless Steel shoulder bolt M10 x 12 x 50LG to 44.7Nm using 6mm hex key.

#### Preferred method

Custom SGS stud 19 x 13 x 70LG stud welded to post.

Note:

- \* Use a threadlocking adhesive when using Stainless Steel shoulder bolt.
- \* Mild Steel shoulder bolt must be hot-dip galvanised in place with post to avoid corrosion.

Caddis Group can supply Stainless Steel shoulder bolts.  
Part No: **SGS\_MS\_SCSB - Preferred method**  
Part No: **SGS\_SS\_M10SB**

#### Post Configurations:

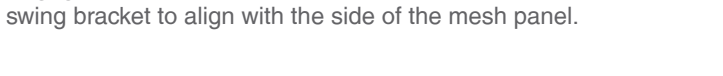

1 - Single

2 - 180°

2 - 90°

3 - Double 90°

4 - Quadruple

### GUARDING PANEL SIZES

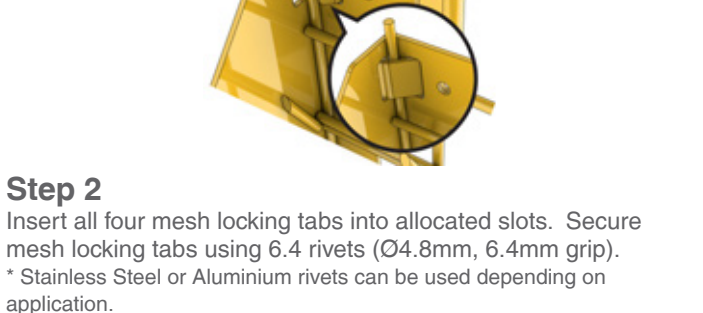

Width may vary for each design. Maximum width of each guard panel cannot exceed 2100mm. We recommend all panels to be under 20kg for a one man operation. All Guarding with a weight of 15kg or over should have a weight indication sign installed.

### GUARDING ASSEMBLY

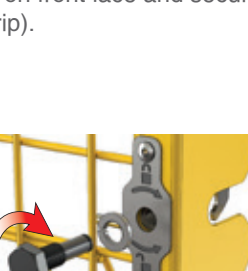

#### Step 1

Engage all bracket hooks onto wire mesh B (2<sup>nd</sup> vertical rod) and swing bracket to align with the side of the mesh panel.

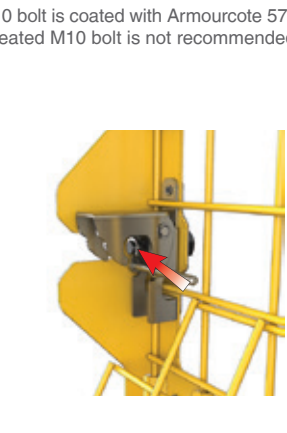

#### Step 2

Insert all four mesh locking tabs into allocated slots. Secure mesh locking tabs using 6.4 rivets (Ø4.8mm, 6.4mm grip).

\* Stainless Steel or Aluminium rivets can be used depending on application.

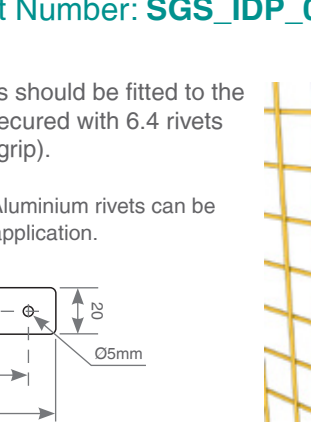

#### Step 3

Slide top tab of latch assembly between wire mesh and bracket. Locate front washer on front face and secure with 6.4 rivets (Ø4.8mm, 6.4mm grip).

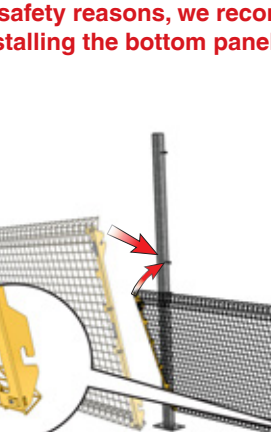

#### Step 4

Screw M10 bolt with spring washer into latch assembly.

\* Stainless Steel 304 M10 bolt is coated with Armourcote 5700 for lubrication purpose. Using a standard non-treated M10 bolt is not recommended to prevent galling.

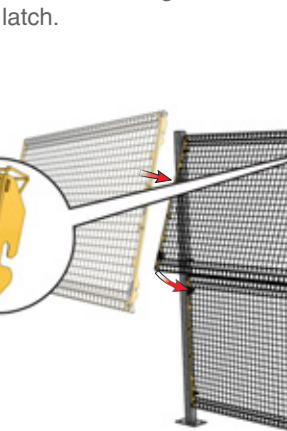

#### Step 5

With the M10 bolt fully engaged, insert the E-clip supplied to ensure the bolt cannot be removed from latch assembly.

### IDENTIFICATION PLATE

Part Number: **SGS\_IDP\_001**

Identification plates should be fitted to the side bracket and secured with 6.4 rivets (Ø4.8mm, 6.4mm grip).

\* Stainless Steel or Aluminium rivets can be used depending on application.

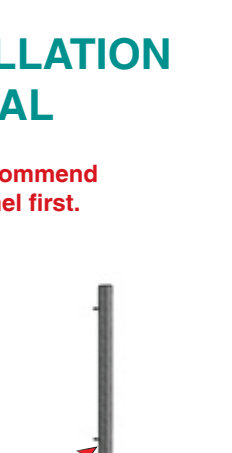
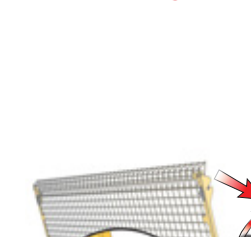

### GUARDING INSTALLATION AND REMOVAL

**For safety reasons, we recommend installing the bottom panel first.**

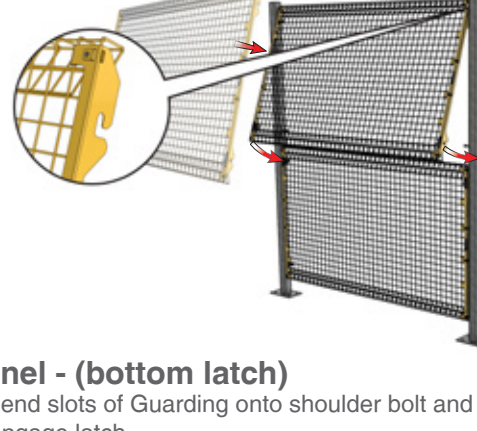

#### Bottom panel - (top latch)

Ensure latch bolt has been undone half way to unlocking position and latch is moving freely.

Hook bottom end slots of Guarding onto shoulder bolt and swing forward to engage latch.

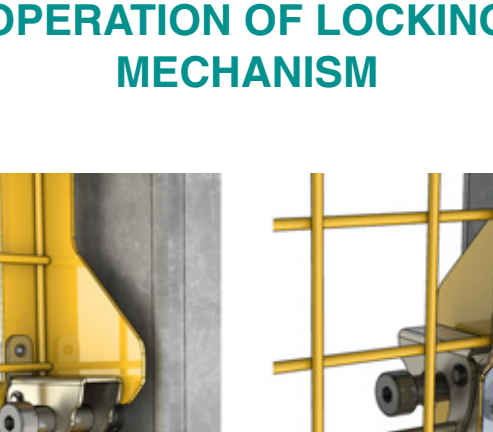

#### Top panel - (bottom latch)

Hook top end slots of Guarding onto shoulder bolt and swing down to engage latch.

#### Locking Guarding Panels

Lock Guarding panel by tightening the M10 locking bolt to 44.7Nm.

Refer to Operation of Locking Mechanism below.

### OPERATION OF LOCKING MECHANISM

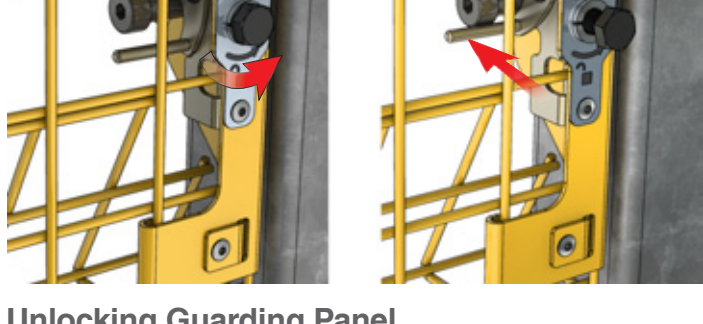

#### Locking Guarding Panel

Once the latch has been engaged with the shoulder bolt, the Guarding Panel is secured. Use a spanner to tighten the M10 bolt to 44.7Nm to lock the Guarding Panel.



#### Unlocking Guarding Panel

Use a spanner to undo M10 bolt for each side brackets to unlock the latch assembly.

While pressing the latch arm, swing Guarding panel out and release latch arm. Allow the external latch groove (shown below) to rest onto the shoulder bolt for easy panel removal.



### CONTACT US

43A Sparks Road,  
Henderson, WA 6163

P (08) 9418 7725  
E [productdesign@caddis.com.au](mailto:productdesign@caddis.com.au)

ABN 79 060 988 767

[sentryguardingsystem.com.au](http://sentryguardingsystem.com.au)